

**Data sheet**





**SONOFLO®**





**Ultrasonic flowmeters**

**Sensor type SONO 4100, SONO 3300, SONO 3100, SONO 3110**

**Signal converter type SONO 3000**

**DN 25 - DN 4000**

Danfoss range of ultrasonic flowmeters	Stainless steel Standard program	Mild steel Standard program	Stainless and mild steel Extended program	Mounting kit for stainless and mild steel
Sensor	SONO 4100 	SONO 3300 	SONO 3100 	SONO 3110 
Size [mm]	DN 25 - DN 80	DN 50 - DN 300	DN 100 - DN 1200	DN 400 - DN 4000
Connection examples	DIN 2501 ANSI B 16.5 150 lbs RF ANSI B 16.5 300 lbs RF			None
Pressure [bar]	PN 40 Class 150, Class 300	PN 10, PN 16, PN 40 Class 150, Class 300	PN 6, PN 10, PN 16, PN 25, PN 40 Class 150, Class 300	Max. PN 40
Temperature max. [°C]	180	160	200	200
Transducer	Integrated version. No assemblies, no gaskets	Integrated transducers	SONO 3200 O-ring type Flange transducers	SONO 3200 O-ring type
Enclosure	IP 67	IP 67	IP 68	IP 68
Approvals	EEx d II C T3-T6		EEx d IIC T2-T6	EEx d IIC T3-T6

Signal converters	SONO 3000			SONO 3000 Ex-d
				
Enclosure	Compact IP 67	19" insert IP 00	19" insert IP 65	Compact IP 67
Mounting	Compact or separate wall mounting	19" rack or wall mounting		Compact or separate wall mounting
Accuracy (Error limit)	0.5% of actual flow			
Materials	Polyamid, AISI 316	ALU	ABS Plastic	AISI 304
Outputs	1 current 1 frq./pulse 1 relay	3 current 2 frq./pulse 2 relays	1 current 1 frq./pulse 1 relay	1 current 1 frq./pulse 1 relay
Display/counter	Alphanumeric: flow, quantity, error, mass flow, sound velocity, etc.			
Language	English, German, French			
Approval	Can be used with any EEx-approved sensor SONO 4100, SONO 3300, SONO 3100 and SONO 3110, when the SONO 3000 is placed in safe area			EEx de [ia/ib] IIC T6
Supply voltage	115/230 V a.c. 24 V a.c./d.c.			24 V a.c./d.c.

**Contents**

Introduction .....	4
System overview .....	4
Application .....	4
SONOFLO® characteristics .....	4
Technical data SONO 4100 .....	5
Technical data SONO 3300 .....	5
Technical data, SONO 3100 .....	6
Technical data, SONO 3110, mounting kit .....	6
Technical data, SONO 3000 .....	7
Technical data, Coaxial cable for SONO 4100, 3300, 3200/3000 .....	8
System accuracy .....	9
Accessories .....	10
Transducer SONO 3200 .....	10
Transducer element .....	10
Transducer insert .....	10
Dimensions and weight, SONO 4100/3300 .....	11
Dimensions and weight, SONO 3100 .....	12
Approximate system weights [kg] .....	13
Signal converter SONO 3000 compact .....	13
Signal converter SONO 3000 19" rack .....	14
Signal converter SONO 3000 Ex d. ....	15
Compact version installation .....	16
Remote installation of signal converter .....	16
Electrical connection 19" insert with: 3 current outputs, 2 frequency/pulse outputs, 2 relay outputs .....	17
Sizing table (DN 25 - DN 4000) .....	18
Location .....	19
Direction of flow .....	19
Full pipes .....	19
Installation in vertical pipes .....	20
Installation in horizontal pipes .....	20
Measuring liquids containing abrasive or other particles .....	21
Inlet and outlet conditions .....	21
Ordering .....	22
Custom built pipe versions .....	27
Mode of operation .....	27

## Introduction

Danfoss SONOFLO® ultrasonic flowmeters are designed for measurement of:

- Volume flow rate
- Total volume
- Mass flow rate
- Total mass
- Sound velocity in the liquid

SONOFLO® ultrasonic flowmeters measure flow in standard volumetric and mass flow units. Measurement is independent of changes in liquid temperature, density, pressure and conductivity.

An ultrasonic time of flight flowmeter is designed for use on clean liquids. A SONOFLO® flowmeter will also operate on liquids containing small amounts of gas and solid particles, due to intelligent signal processing.

SONOFLO® ultrasonic flowmeters measure with a high accuracy (better than 0,5% of reading over a wide measuring range).

The SONO 3000 signal converter is common to all sensors and is 115/230 V a.c. or 24 V a.c./d.c. compatible. An Ex-version is available.

## System overview

Sensor type	Signal converter	Outputs	Measurement
SONO 4100 DN 25 - DN 80	SONO 3000 Standard housing	<ul style="list-style-type: none"> <li>• 1 analog</li> <li>• 1 frequency-/pulse</li> <li>• 1 relay</li> </ul>	<ul style="list-style-type: none"> <li>• Volume flow rate</li> <li>• Total volume</li> <li>• Mass flow rate</li> <li>• Total mass</li> <li>• Sound velocity</li> </ul>
SONO 3300 DN 50 - DN 300	SONO 3000 AISI 316 housing	<ul style="list-style-type: none"> <li>• 1 analog</li> <li>• 1 frequency-/pulse</li> <li>• 1 relay</li> </ul>	
SONO 3100 DN 100 - DN 1200	SONO 3000 Ex-d AISI 304 housing	<ul style="list-style-type: none"> <li>• 1 analog</li> <li>• 1 frequency-/pulse</li> <li>• 1 relay</li> </ul>	
SONO 3110 DN 400 - DN 4000	SONO 3000 19" Insert SONO 3000 19" Insert	<ul style="list-style-type: none"> <li>• 1 analog</li> <li>• 1 frequency-/pulse</li> <li>• 1 relay</li> <li>• 3 analog</li> <li>• 2 frequency-/pulse</li> <li>• 2 relays</li> </ul>	

## Application

Accurate and obstruction-free flow measurement of conductive and non-conductive liquids. A new compact design enables SONOFLO® meters to fit into a wide variety of installations.

## SONOFLO® characteristics

- Compact steel construction with transducers integrated into the pipe wall
- Use of Digital Signal Processing (DSP) ensures fast response, reliable signal recognition and high time resolution
- Long-life stability due to fully digital signal processing
- Transducers can be replaced during operation
- Fully welded construction with no gaskets and no gap corrosion

**Technical data  
SONO 4100**

Description	2 track sensor with flanges and integrated transducers
Nominal size	DN 25, DN 32, DN 40, DN 50, DN 65, DN 80 (1" - 3")
Liquid temperature	Separate version – 40 °C to +180 °C
	Compact version – 20 °C to +120 °C
	Compact EEx d – 20 °C to +180 °C
Ambient temperature	Separate version – 40 °C to +180 °C
	Compact version – 20 °C to +55 °C
	In stock – 40 °C to +70 °C
Enclosure	Ex version compact EEx de [ia/ib] IIC T5-T6
	Ex version separate EEx de [ia/ib] IIC T6
Process connections BS 4504/DIN 2501 ANSI B 16.5	PN 40
	Class 150 lbs (PN 20)
	Class 300 lbs (PN 50)
Flange type	Welding neck
Transducer	Integrated version. No assemblies, no gaskets
Materials:	
Flanges and transducers	AISI 316L (W 1.4435)
Piping	AISI 316 (W 1.4404)
Material certificate on	The sensor is supplied as standard with a Danfoss certificate of conformity (standard). Material certificate on wetted parts request
Welding certificate	Welding certificate is available on request. All weldings are tested by radiographic tests (on wetted parts)
Max. flow velocity DN 25 - DN 80	10 m/s

**Technical data  
SONO 3300**

Description	2 track sensor with flanges and integrated transducers
Nominal size	DN 50, DN 65, DN 80, DN 100, DN 125, DN 150, DN 200, DN 250, DN 300 (2" - 12")
Liquid temperature:	Separate version – 40 °C to +160 °C
	Compact version – 20 °C to +120 °C
	Compact EEx d – 20 °C to +160 °C
Ambient temperature	Separate version – 40 °C to +160 °C
	Compact version – 20 °C to +55 °C
	In stock – 40 °C to +70 °C
Enclosure	Standard version IP 67
	Ex version compact EEx de [ia/ib] IIC T5-T6
	Ex version separate EEx de [ia/ib] IIC T6
Process connections BS 4504/DIN 2501	DN 50 - DN 300 PN 40
	DN 100 - DN 300 PN 16
	DN 200 - DN 300 PN 10
ANSI B 16.5	DN 125 - DN 300 (5" - 12) Class 150 lbs (PN 20) DN 50 - DN 300 (2" - 12) Class 300 lbs (PN 50)
Transducer	Integrated version welded into pipe Exchangeable during operation (active parts)
Transducer material	AISI 316 (W 1.4436)
Materials:	
Pipe and transducer holder	DN 50 - DN 150: Mild steel W. 1.1131 DN 200 - DN 300: Mild steel W. 1.0254 (St. 37 WB)
Flange material	DN 50 - DN 300: Mild steel W. 1.0402 C22
Material certificate on	The sensor is supplied as standard with a Danfoss certificate of conformity (standard). Material certificate on wetted parts request
Welding certificate	Welding certificate is available on request. All weldings are tested by radiographic tests (on wetted parts)
Max. flow velocity DN 50 - DN 300	10 m/s

**Technical data  
SONO 3100**

Description	2 track sensor fitted with four SONO 3200 transducers		
Nominal size	DN 100 - DN 1200 ( 4" - 48")		
Liquid temperature	Standard version	-20 °C to +200 °C	
Ambient temperature	Standard version	-20 °C to +200 °C	
Enclosure	Ex version	EEx d IIC T2-T6, IP 68	
Materials: DN 100 - DN 300			
Pipe material	AISI 316		
Flange material	AISI 316		
Materials: DN 350 - DN 1200			
Pipe material	Mild steel	W.1.0305	St. 35.8
Flange material	Mild steel	W.1.0460	C 22.8
Terminal box	Standard version	AISI 316	200 °C
Transducer element	Standard version	AISI 316	200 °C
Material certificate	The sensor is supplied as standard with a Danfoss certificate of conformity (standard). Material certificate on wetted parts on request		
Welding certificate	Welding certificate is available on request. All weldings are tested by NDT, either radiographic or ultrasonic tests on parts		
wetted			
Max. flow velocity DN 100 - DN 1200	10 m/s		

**Technical data  
SONO 3110 mounting kit**

Introduction	Kit for mounting on existing steel, concrete pipes or cast iron with appropriate "saddle"		
Description	SONOFLO® mounting kit consists of transducers, transducer holders, special tool and instructions		
Line pressure	Max. 40 bar		
Liquid temperature	Standard version	-20 °C to +100 °C	
	High-temperature version	-20 °C to +200 °C	
Enclosure	Standard version	IP 68	
	Ex version	EEx d IIC T3-T6, IP 68	
Materials:	Standard version	PA 6.6	100 °C
Terminal box	AISI 316 200 °C		
Transducer element	Standard version	AISI 316 with ceramic-coated window	150 °C
	High-temperature version	AISI 316	200 °C
Material of existing pipeline			
Steel	Transducer holder:	St. 37.2 or equivalent	
	Mounting plate:	St. 37.2 or equivalent	
Concrete	Transducer holder:	AISI 316	
Stainless steel	Transducer holder:	AISI 316	
	Mounting plate:	AISI 316	
Pipe wall thickness			
Steel pipe (AISI 316 and St. 37.2 or corresponding material)	Transducer and holder available in length L = 160 Allowing a pipewall thickness up to 20 mm		
Concrete pipe	Transducer available in lengths L = 160 or L = 230 Allowing a pipewall thickness up to 200 mm		

**Note:**

The standard transducer angle is 60°.

SONO 3110 mounting kit is not suitable for pipe diameters less than DN 400.

## Technical data

## Signal converter SONO 3000

		Terminal connection
<b>Analog output: 1, 2 and 3</b>	Individually galvanically isolated, isolation voltage 500 V	31 and 32
Measurement of: (optional via menu)	Volume flow, mass flow, sound velocity	33 and 34
Current	0-20 mA or 4-20 mA	35 and 36
Load	< 800 ohm (EEx-d < 370Ω)	
Time constant	0.8 - 30 s adjustable	
<b>Frequency/pulse output: 1 and 2</b>	Individually galvanically isolated, isolation voltage 500 V	50, 51 and 52
Measurement of: (optional via menu)	Volume flow, mass flow, sound velocity, total volume, total mass	54, 55 and 56
Frequency	0-10 kHz	
Time constant	0.8 - 30 s adjustable	
Pulse width	50 μs, 500 μs, 50 ms E. Mech, 500 ms, 1 s, 5 s	
<b>Active:</b> Output mode	24-30 V d.c./max. 25 mA, (50 μs to 5s)	
	(50 ms E.Mech., max. 75 mA if F < Hz)	
	24 - 30 V d.c./max. 50 mA, (500 Hz to 10 kHz)	
	(EEx-d, approx. 28V, internal resistor = 470 ohm)	
<b>Passive:</b> Output mode	5 - 30 V d.c. (EEx-d, 5-28V)	
	Max. current 200 mA	
<b>Output mode:</b>	Output 1 and 2 can be set in active or passive mode individually, by electrical connection	
<b>Relay 2</b>	Change-over relay (flow direction, sound velocity limit)	41, 42 and 43
Load	42 V, 0.5 A	
Time constant/Hysteresis	5 s/0,5% F.S.O.	
<b>Relay 1</b>	Change-over relay (error indication, flow direction, sound velocity limit)	44, 45 and 46
Load	42 V, 0.5 A	
Time constant/Hysteresis	5 s/0,5% F.S.O.	
<b>Cut off:</b> Low flow	0-9.9% F.S.O.	
<b>Supply voltage and power consumption</b>	115/230 V a.c. +10% to -15%, 50-60 Hz, 10-20 VA	PE, N and L
	24 V d.c. +25/-15%, 24 V a.c. ± 15%, 10 VA	PE, 1 and 2
<b>Internal counters (totalizers)</b>	Two internal counters. Selectable uni- or bidirectional counting (Nett. flow).	
Measurement of	total volume, total mass	
<b>Display</b>	Back-lit with alphanumeric text, 2 x 16 digits for indication of: measured values, totalization, settings, error codes and alarms	
<b>Ex d-version</b>		
Enclosure	Compact mounted: IP 67 to IEC 529 and DIN 40050 Separate mounted: IP 65 to IEC 529 and DIN 40050	
Material	AISI 304 (W 1.4301)	
Dimensions	See page 15	
Weight	Approx. 11 kg	
Ambient temperature	Operation: -20 °C to +55 °C Storage: -40 °C to +85 °C	
Supply voltage and power consumption	24 V d.c. + 25/-15%, 24 V a.c. ±15%, 10 VA, cable impedans < 10 ohm at 24 V	PE, N and L PE, 1 and 2
Description of Ex-approval	EEx de [ia/ib] II C T6 Flame proof Enclosure "d" Outputs intrinsically safe class "ia" Display/keypad intrinsically safe class "ib" Power and sensor connections are increased safe "e" Separate version: DEMKO No. 94C.113341X	
<b>Enclosure 19" insert</b>		
Enclosure	IP 00 to IEC 529 and DIN 40050	
Material	Standard 19" insert in aluminium/steel (DIN 41494)	
Dimensions	Width: 142 mm Height: 128 mm Module depth: 190 mm	
Weight	2.8 kg	
Mechanical vibration	1G 1-800 Hz sinusoidal in all directions to IEC 68-2-6	
Ambient temperature	Operation +0 °C to +55 °C Storage -40 °C to +85 °C	
Supply voltage and power consumption	24 V d.c.+ 25/-15%, 24 V a.c. ±15%, 15 VA, cable impedans < 7 ohm at 24 V	PE, N and L PE, 1 and 2

**Technical data**                      **Signal converter SONO 3000**

<b>Enclosure compact</b>			
Enclosure	IP 67 to IEC 529		
Material	Fibre glass reinforced polyamide		
	Option: Stainless steel		
Dimension	Width: 148 mm		
	Height: 178 mm/225 mm		
	Depth: 124 mm		
Weight:	Approx. 2 kg		
Ambient temperature	Operation: -20 °C to +55 °C		
	Storage: -40 °C to +85° C		
Supply voltage and power consumption	24 V d.c. + 25/-15%, 24 V a.c. ±15%, 10 VA, cable impedans < 10 ohm at 24 V	PE, N and L PE, 1 and 2	
<b>Electromagnetic compatibility (EMC)</b>	CENELEC	Emission	Immunity
		EN 50081-1	pr. EN 50082-2

**Technical data**                      **Coaxial cable for SONO 4100, 3300, 3200/3000**

<b>Coaxial cable</b>		Coaxial cable	
Diameter	∅ 8 mm		
Length	Max. 100 m between sensor and signal converter		
Material	PVC		
Ambient temperature	-10 °C to +100 °C		
<b>Coaxial cable</b>			
Diameter	∅ 5.3 mm		
Length	Max. 100 m between sensor and signal converter		
Material	PTFE		
Ambient temperature	-200 °C to +200 °C		
<b>Multi coaxial cable</b>			
Diameter	∅ 10 mm		
Length	Max. 20 m between sensor and signal converter		
Material	PVC		
Ambient temperature	-10 °C to +70 °C		
<b>Twinax cable</b>		Electrical connection between sensor and signal converter	
		4 x 2 x 0.38 mm <sup>2</sup> twisted and screened in pairs	
Diameter	∅ 12 mm		
Length	Max. 10 m		
Material	PTFE		
Ambient temperature	-200 °C to +200 °C		

## System accuracy

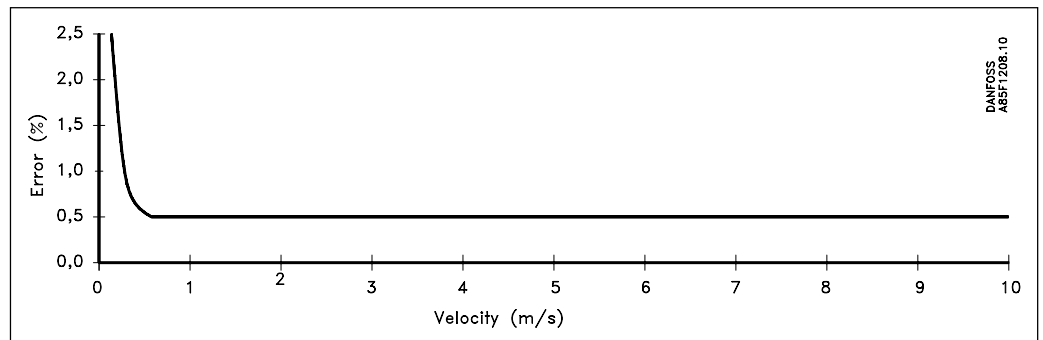
**Reference conditions:**

- Fluid: Water
- Fluid temperature:  $22 \pm 5$  °C
- Ambient temperature:  $22 \pm 5$  °C
- Supply voltage:  $230 \pm 12$  V and  $24$  V  $\pm$  3.6 V
- Straight length:  $20 \times D_i$

Rangeability: 0 - 1 m/s to 0 - 10 m/s

Repeatability: Better than 0,25% in the range from 0,5 m/s to 10 m/s

Linearity: Better than 0,4% for Reynolds number  $> 5000$

Better than 1% for Reynolds number  $1000 < Re < 5000$

**Additional effects of deviations from reference conditions**

1. Current output: As frequency output  $\pm$  (0,1% of actual flow +0,05% FSO)
2. Effect of ambient temperature: Display/frequency/pulse output:  $< 0.005\%$  SPAN/K
3. Current output:  $< \pm 0.0075\%$  SPAN/K
4. Effect of supply voltage: 0,005% of measuring value at 1% change
5. SONO 3300 DN 50 and DN 65  $\pm 0.5\%$  for Reynolds numbers  $1000 < Re < 5000 \pm 1.5\%$
6. System accuracy SONO 3100 2-track  $\pm 0.15\%$  F.S.O.
7. Theoretical calibration SONO 3110: 0.5% - 1.5%

## Accessories

## Extraction tool

Transducer SONO 3200 can be removed from the pipe section without draining the pipe using the extraction tool which is provided with a standard ball valve.



## Valve specification

Connection BSP 1 1/2 internal  
Orifice min.  $\varnothing$  40 mm  
Length max. 115 mm

Transducer  
SONO 3200

Transducers are available in two versions: Flange type or O-ring type.  
Transducers are constructed in three parts:

1. Terminal box (See page 12)
2. Transducer element
3. Insert

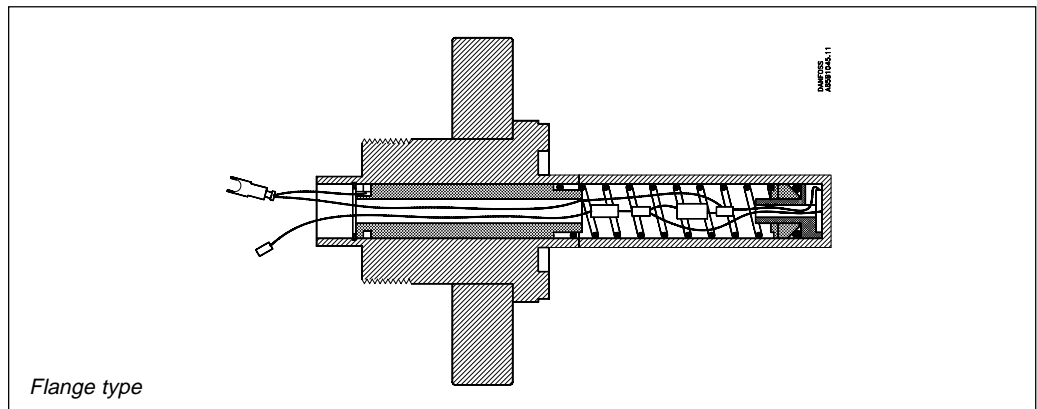

Terminal box, transducer element and insert are identical in both versions.  
The ultrasonic pulse is produced by sound energy being transmitted, via the window, to/from the liquid. The sound source is a piezoelectric crystal in the insert.  
The insert, consisting of a spring and piezo crystal, can be removed from the transducer element during operation. No draining is necessary as the transducer element remains in the pipe.

## Transducer element

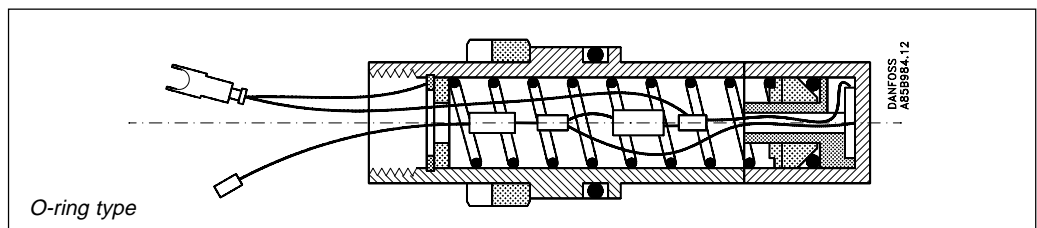

## Transducer insert

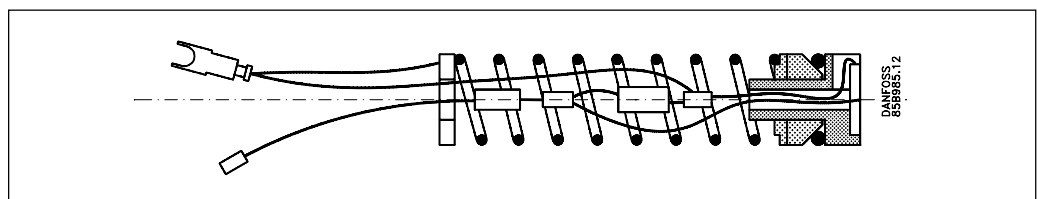

## Dimensions and weight SONO 4100/3300

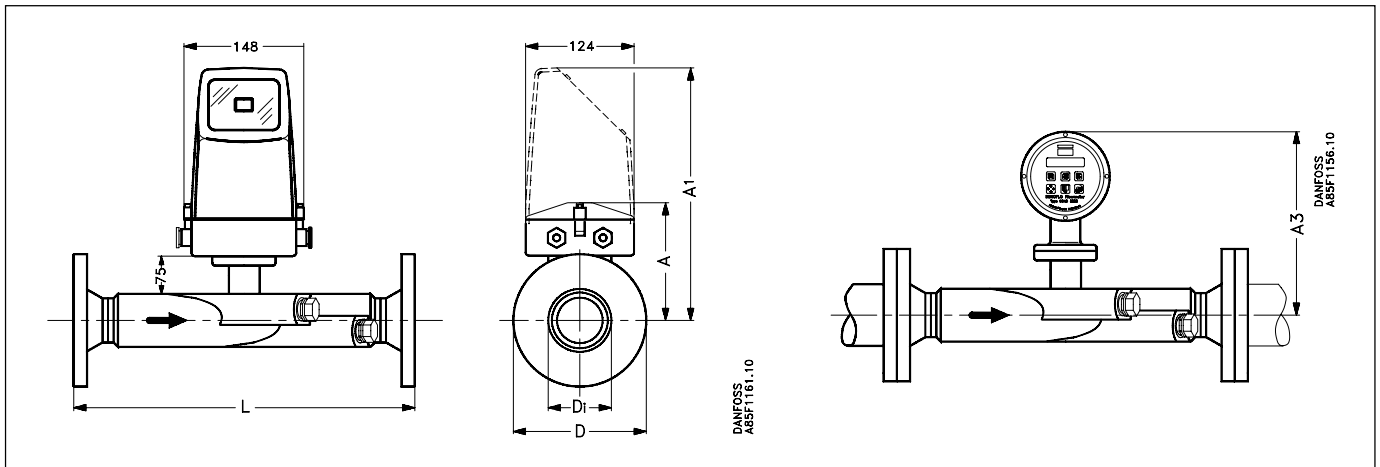

## SONO 4100

DN	DIN 2501 / ANSI 16.5 B RF / BS 4504			Without SONO 3000	With SONO 3000	With SONO 3000 EEx d	Weight DIN, PN 40	Weight ANSI, 300 lb	
	PN 40		150 lb						300 lb
	L	D	Di						Di
25	300	124	26.7	142	298	259	8	15	
32	300	140	35.0	145	301	262	10	17	
40	300	155	41.0	154	310	271	12	19	
50	300	165	52.6	162	318	279	14	21	
65	300	190	62.7	171	327	288	18	25	
80	300	210	78.0	177	333	294	22	30	

## SONO 3300

DN	DIN 2632/2633/2635									ANSI						Without SONO 3000	With SONO 3000	Weight*) DIN PN 40	Weight*) ANSI Cl.300
	PN 10			PN 16			PN 40			150 lb			300 lb						
	L	D	Di	L	D	Di	L	D	Di	L	D	Di	L	D	Di				
50							475	165	52.6				520	165	52.6	191	348	(14)	17
65							475	185	62.7				520	190	62.7	197	354	(16)	20
80							400	200	78.0				440	210	78.0	203	360	19	23
100				375	220	102.4	400	235	102.4				440	254	102.4	216	373	25	35
125				375	250	128.3	400	270	128.3	440	254	128.3	460	279	128.3	229	386	29	40
150				360	285	154.2	400	300	154.2	430	279	154.2	450	318	154.2	243	400	35	50
200	400	340	207.9	400	340	207.9	450	375	206.5	480	343	202.7	500	381	202.7	255	412	54	72
250	400	395	260.4	400	405	260.4	500	450	258.8	490	406	254.5	520	444	254.5	282	439	85	98
300	400	445	309.7	420	460	309.7	500	515	307.9	550	483	304.8	580	521	304.8	307	464	115	142

\*) When mounting the signal converter, the weight increases by 2 kg, with the EEx signal converter, the weight increases by 10 kg.

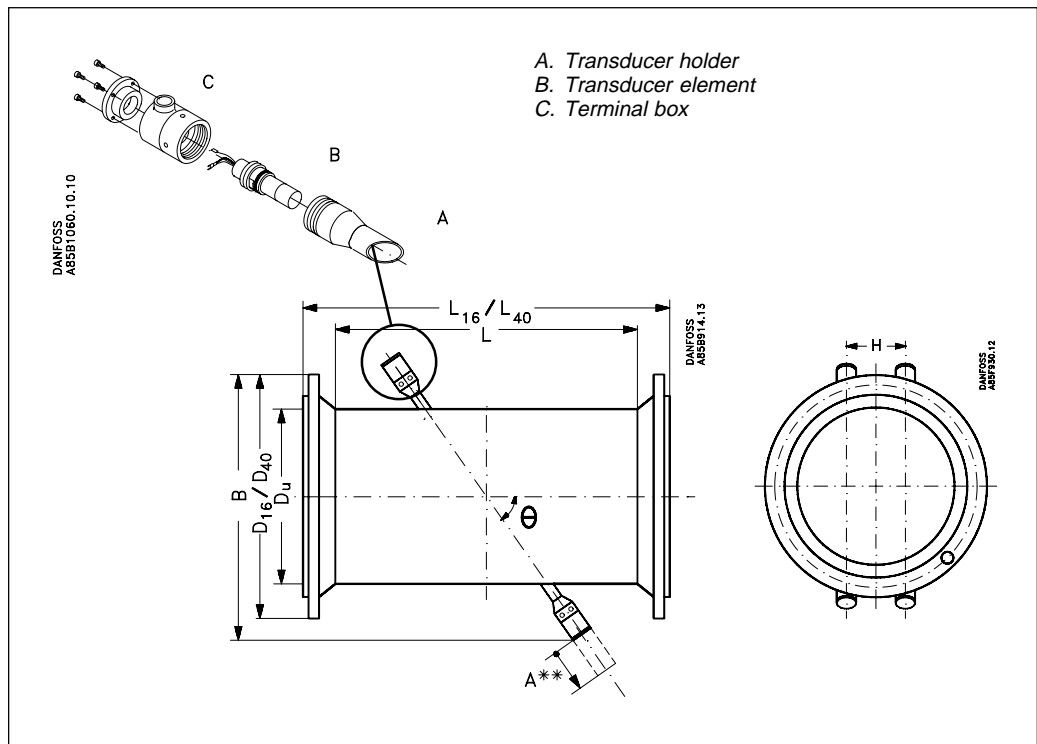
**Dimensions and weight  
SONO 3100**

DN	D <sub>u</sub> (mm)	L (mm)	B (mm)	θ [°]	H (mm)	PN 6			PN 10			PN 16			PN 25			PN 40		
						W <sub>6</sub> *) (mm)	D <sub>6</sub> Flange dia. (mm)	L <sub>6</sub> (mm)	W <sub>10</sub> *) (mm)	D <sub>10</sub> Flange dia. (mm)	L <sub>10</sub> (mm)	W <sub>16</sub> *) (mm)	D <sub>16</sub> Flange dia. (mm)	L <sub>16</sub> (mm)	W <sub>25</sub> *) (mm)	D <sub>25</sub> Flange dia. (mm)	L <sub>25</sub> (mm)	W <sub>40</sub> *) (mm)	D <sub>40</sub> Flange dia. (mm)	L <sub>40</sub> (mm)
100	114.3	860	305	30	48.2	-	-	-	3.6	220	800	3.6	220	960	3.6	235	990	3.6	235	990
125	139.7	862	325	30	59.3	-	-	-	4.0	250	810	4.0	250	970	4.0	270	990	4.0	270	990
150	168.3	862	350	30	71.7	-	-	-	4.5	285	810	4.5	285	970	4.5	300	1010	4.5	300	1010
200	219.1	668	430	45	92.9	-	-	-	6.3	340	630	6.3	340	790	6.3	360	820	6.3	375	840
250	273.0	714	480	45	117.2	-	-	-	6.3	395	690	6.3	405	850	7.1	425	890	7.1	450	920
300	323.9	607	525	45	139.4	-	-	-	7.1	445	740	7.1	460	760	8.0	485	790	8.0	515	830
350	355.6	639	550	45	152.8	-	-	-	8.0	405	770	8.0	520	800	8.0	555	840	8.8	580	880
400	406.4	703	600	45	175.7	-	-	-	8.0	565	850	8.0	580	875	8.8	620	925	11.1	660	975
500	508.0	797	690	45	222.2	-	-	-	7.1	670	950	8.0	715	980	10.0	730	1050	14.2	755	1080
600	610.0	912	705	60	268.1	-	-	-	7.1	780	1075	8.8	840	1105	11.0	845	1165	-	-	-
700	711.0	937	895	60	312.8	-	-	-	8.0	895	1100	8.8	910	1140	12.5	960	1190	-	-	-
800	813.0	967	985	60	358.7	-	-	-	8.0	1015	1150	10.0	1025	1180	14.2	1085	1240	-	-	-
900	914.0	1007	1070	60	402.3	-	-	-	10.0	1115	1200	10.0	1125	1230	16.0	1185	1300	-	-	-
1000	1016.0	1060	1160	60	448.2	-	-	-	10.0	1230	1250	10.0	1255	1300	17.5	1320	1370	-	-	-
1200	1220.0	1100	1350	60	539.1	8	1340	1280	11.0	1455	1330	12.5	1485	1360	-	-	-	-	-	-

\*) Wall thickness

A\*\*) Space required for replacement of transducer with special tool: 700 mm  
See also "Space required for replacement of transducer"

Approximate system weights [kg]

2-track DN	O-ring type Weight (kg)					2-track DN	Flange type Weight (kg)				
	PN 6	PN 10	PN 16	PN 25	PN 40		PN 6	PN 10	PN 16	PN 25	PN 40
350		98	113	145	191	100		32	32	35	35
400		119	141	191	275	125		38	38	44	44
500		153	207	284	379	150		45	45	52	52
600		193	276	363		200		59	58	70	79
700		262	303	480		250		73	75	96	117
800		329	400	650		300		83	92	114	151
900		428	475	835							
1000		500	594	1078							
1200	470	732	902								

Weight of system incl. process flanges and transducers

Signal converter  
SONO 3000 compact

Signal converter installed in compact mode

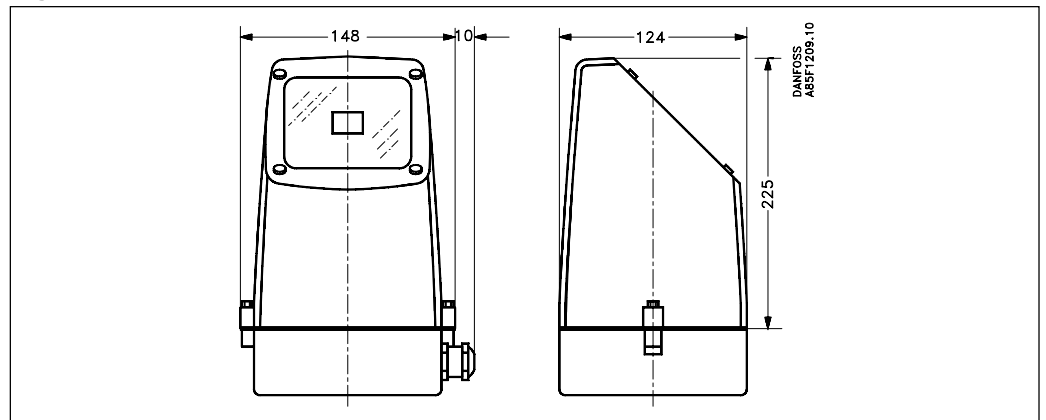

Weight: SONO 3000 approx. 2.0 kg

Signal converter installed separately

Signal converter shown with wall bracket

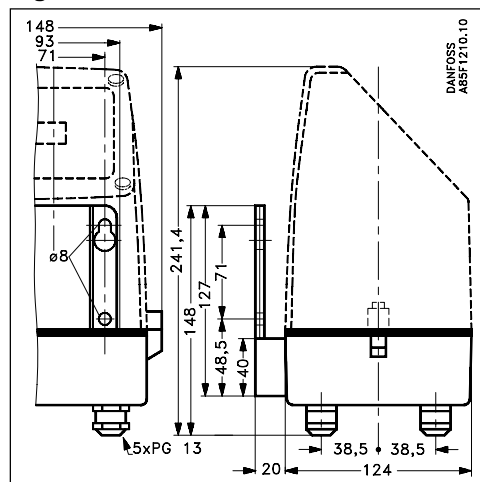

Weight: Wall bracket with pipe clamp  
approx. 1.6 kg

Pipe clamp for mounting bracket

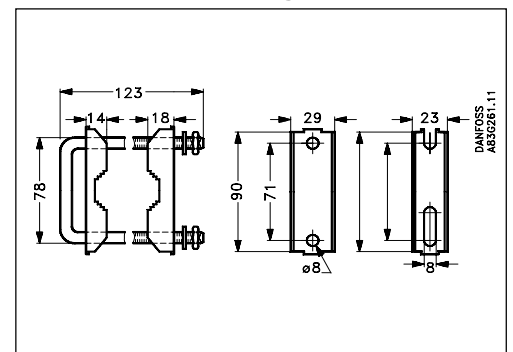

Signal converter  
SONO 3000 19" rack

Signal converter as 19" rack module

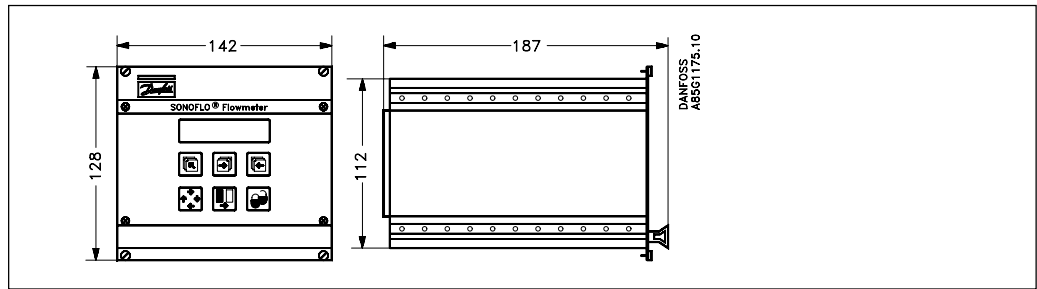

Weight: SONO 3000 approx. 2.8 kg

19" rack module shown with IP 65 wall mounting enclosure

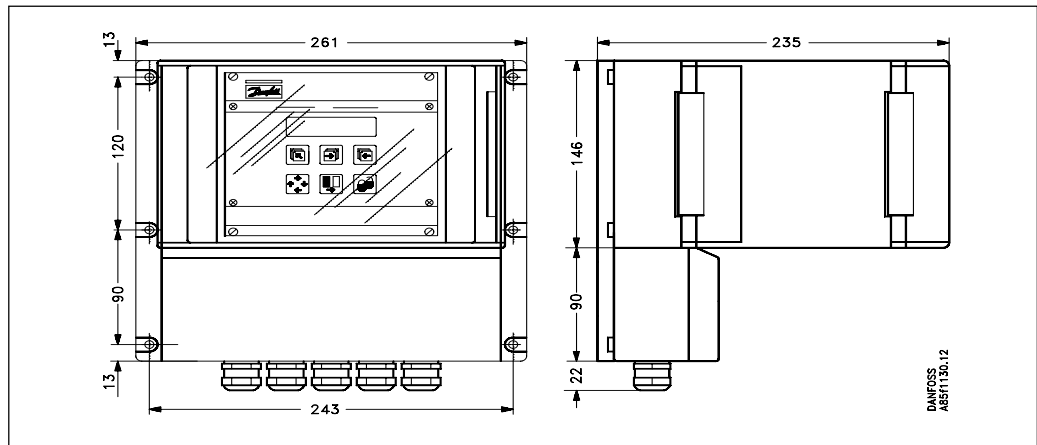

Weight: 19" rack module with IP 65 wall mounting enclosure approx. 3.5 kg

IP 65 panel mounting kit for 19" rack module

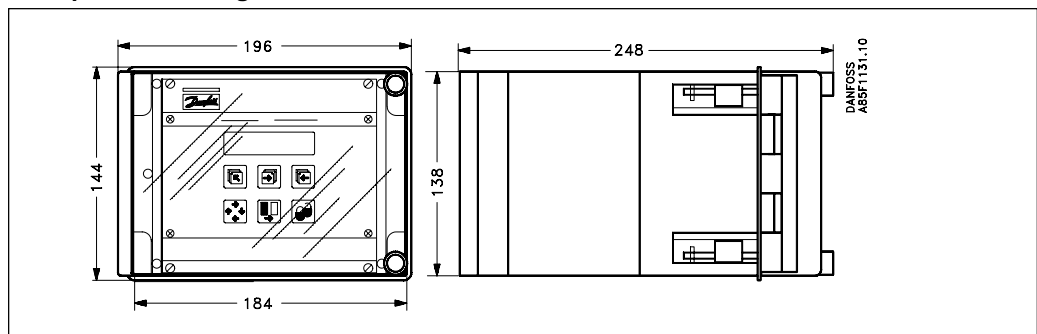

Weight: Panel mounting kit approx. 2 kg

SONO 3000 19" rack module with back of panel mounting kit

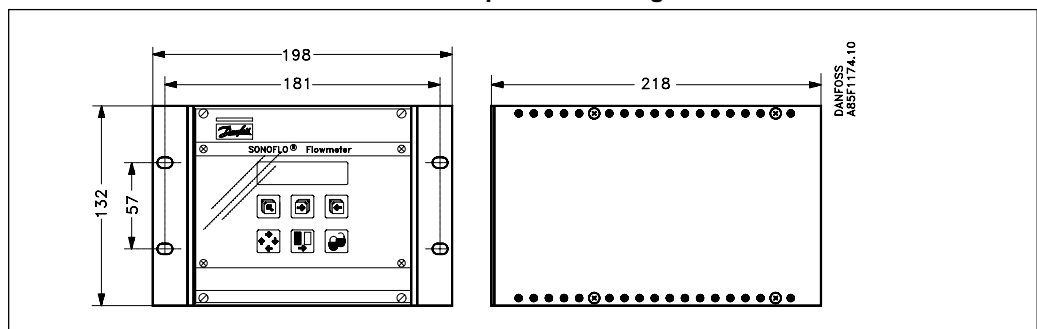

Weight: SONO 3000 19" rack module with back of panel mounting kit approx. 1 kg

Compact version installation

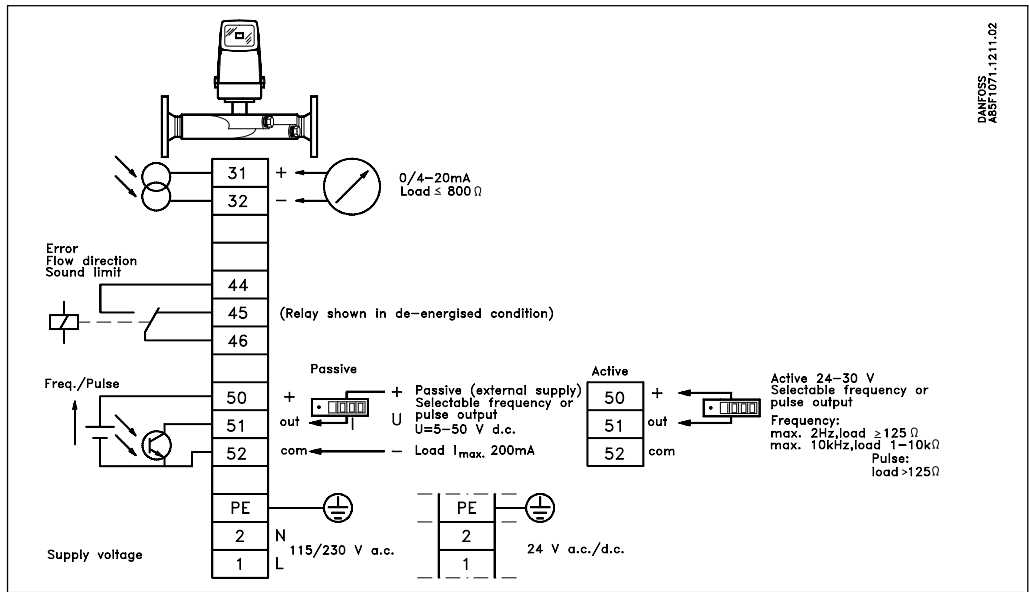

Remote installation of signal converter

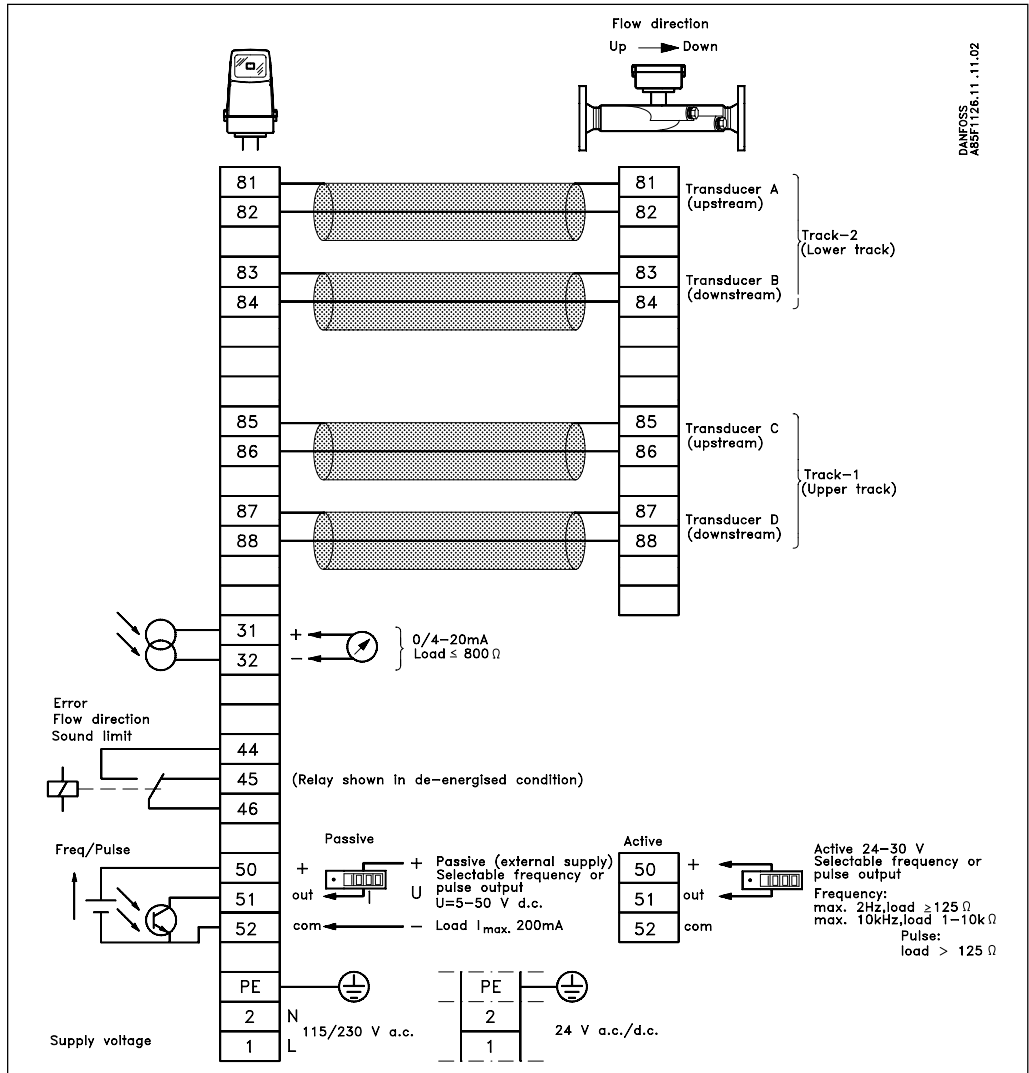

Connect the screens to 81, 83, 85 and 87.

Electrical connection 19" insert with: 3 current outputs, 2 frequency/pulse outputs, 2 relay outputs

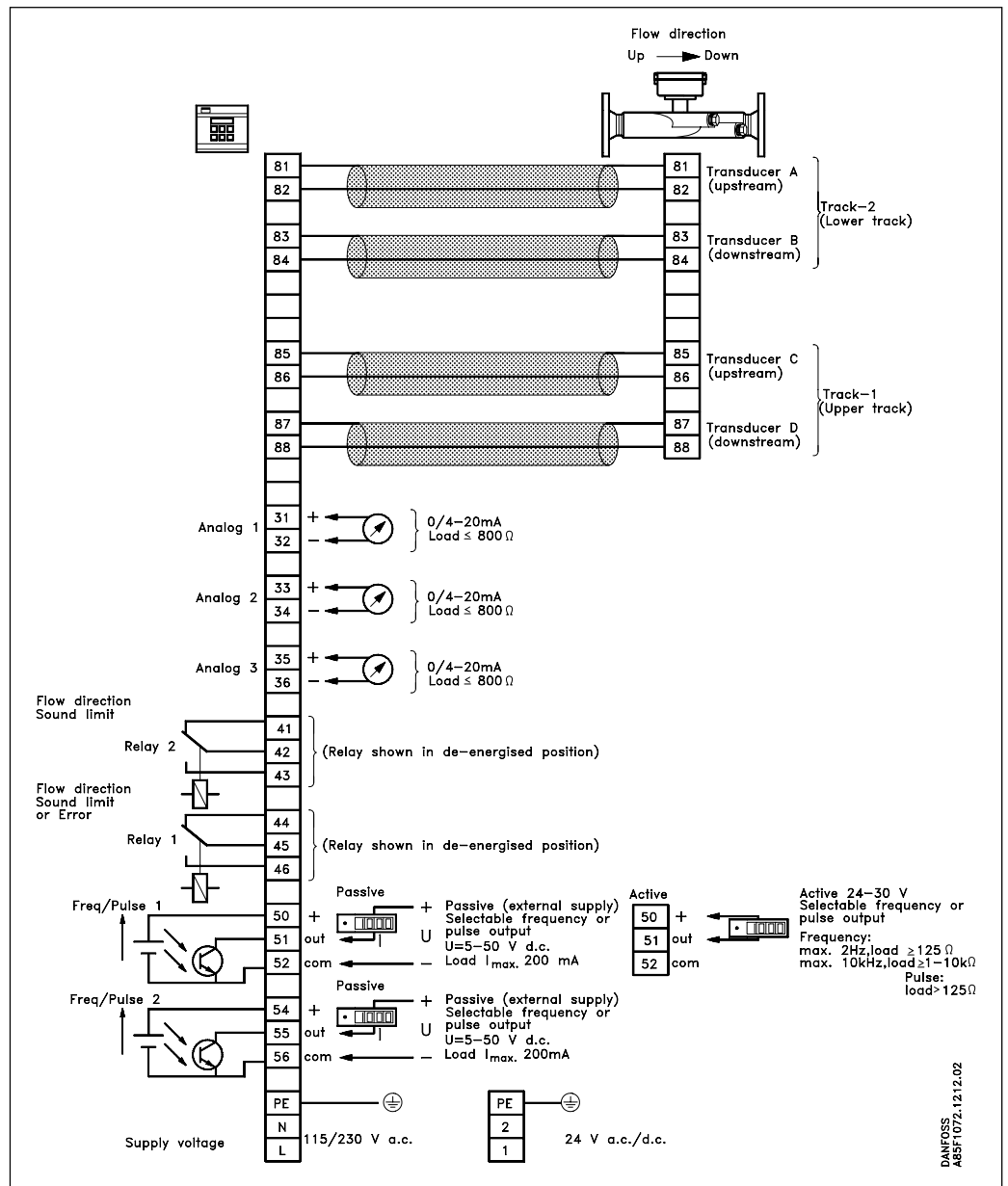

Connect the screens to 81, 83, 85 and 87.

Sizing table  
(DN 25 - DN 4000)

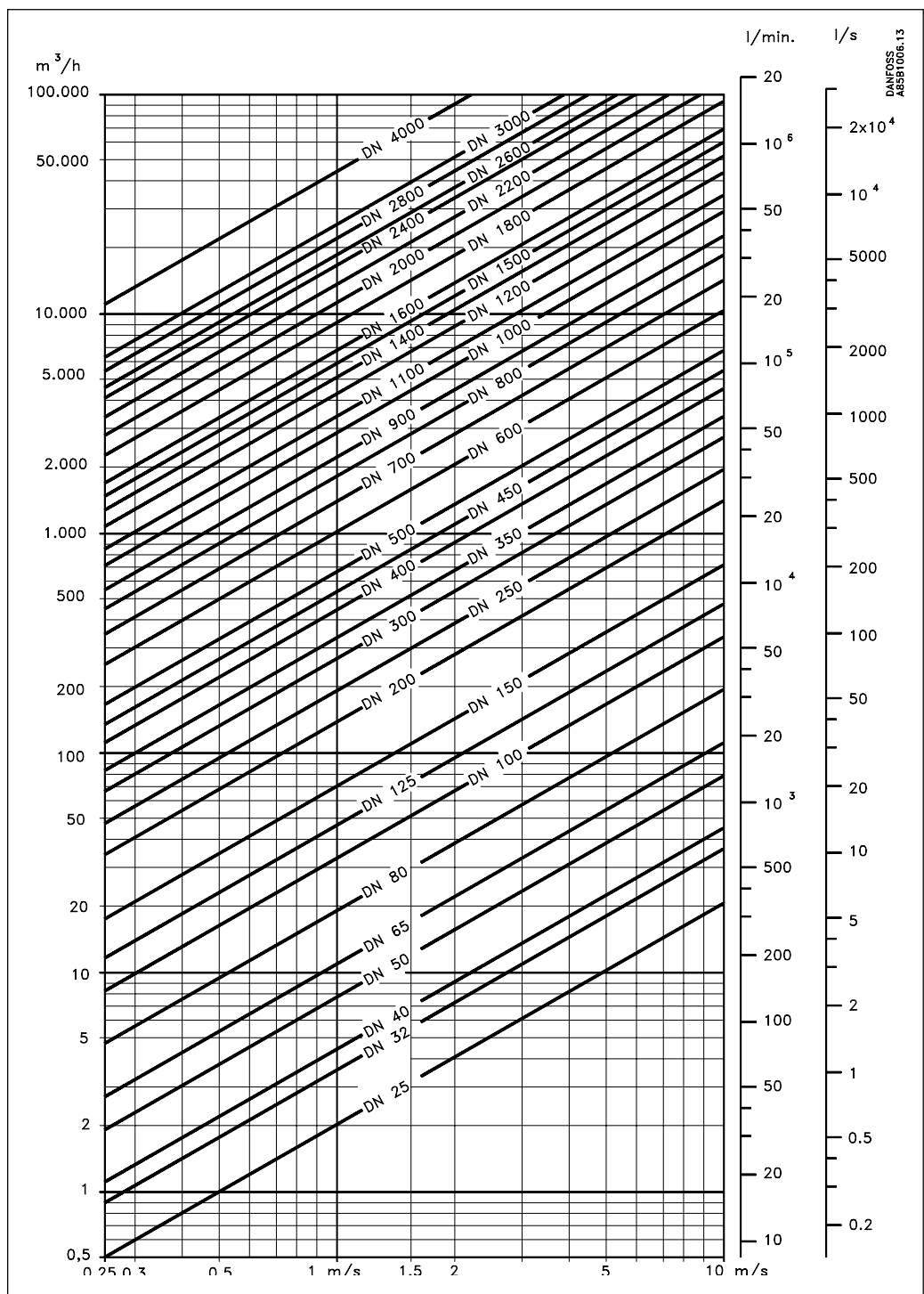

**Location**

The SONO 4100/3300/3100 sensor can be installed both inside or outside in exposed conditions.

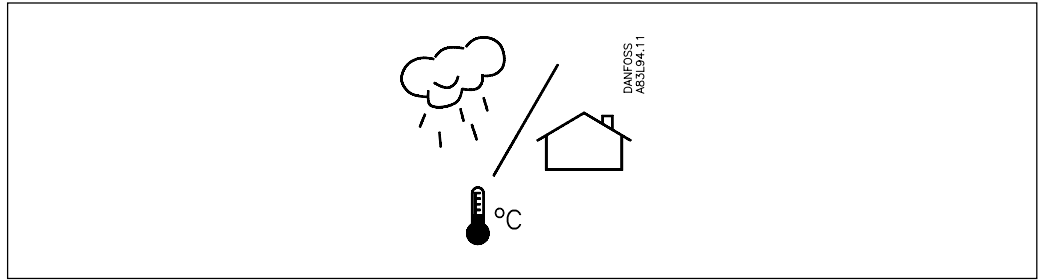

The sensor is suitable for liquid and ambient temperatures from  $-40\text{ }^{\circ}\text{C}$  to  $+200\text{ }^{\circ}\text{C}$ . Temperature limitations are stated on the data plate on the sensor. The enclosure rating is IP 67 or better. SONO 3200 is IP 68 as standard.

When there are large temperature differences between the liquid and the ambient conditions, the sensor must be insulated to prevent 2-phase flow which can result in measuring inaccuracy or measurement failure.

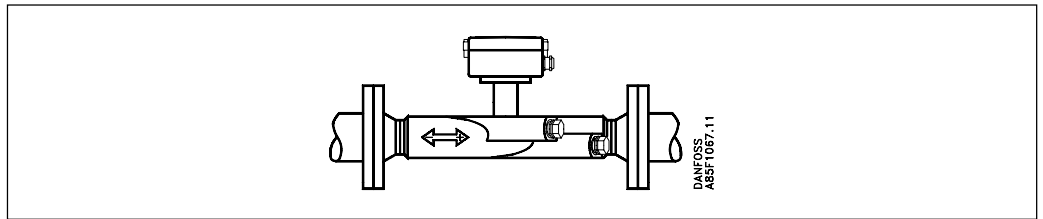
**Direction of flow**

The double arrow is marked "+" and "-".

+ indicates the direction of the flow, if the electrical installation is in accordance with the description in the manual.

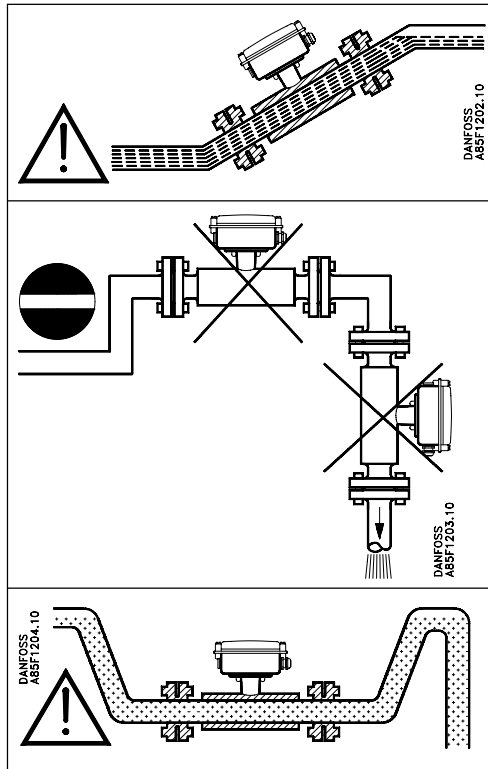
**Full pipes**

The sensor must always be completely full of liquid.

Avoid:

- installation at the highest point in the system.
- installation in vertical pipes with free outlet

With partially full pipes or pipes with free outlet, the flowmeter should be located in a U-tube.

### Installation in vertical pipes

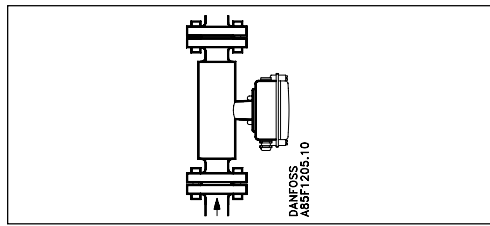

Recommended direction of flow: upwards. This minimizes the effects of gas/air bubbles on the measurement.

### Installation in horizontal pipes

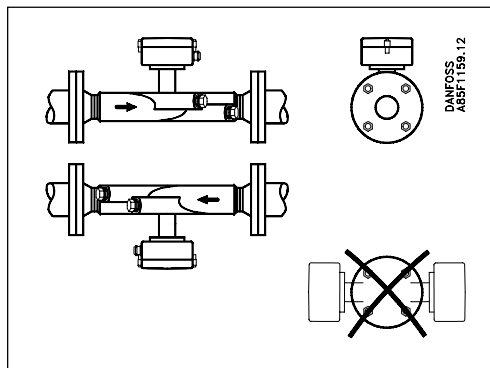

The sensor must be mounted as shown in the diagram.  
Note the position of the terminal box.

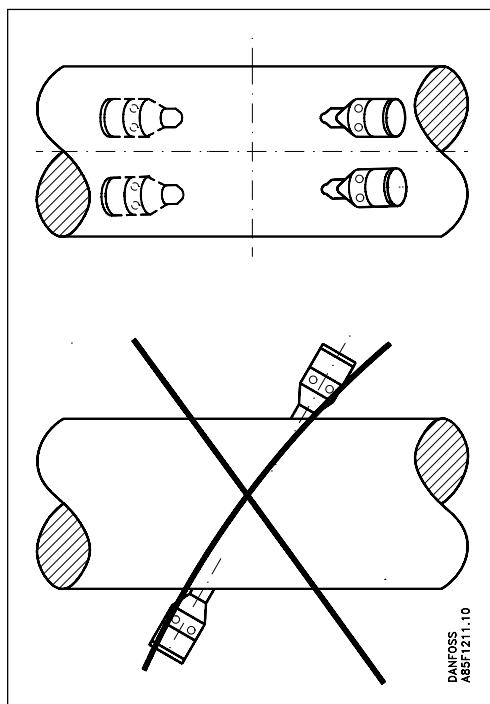

Sensor type SONO 3100 without terminal box must not be mounted with the transducers in the vertical plane.

### Measuring liquids containing abrasive or other particles

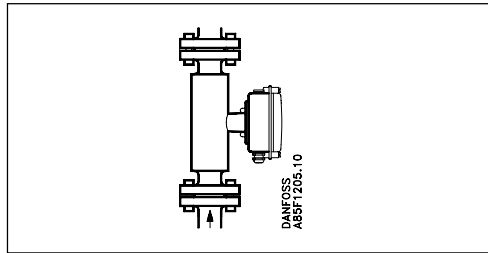

It is preferable to mount the sensor in a vertical line to minimise wear.

### Inlet and outlet conditions

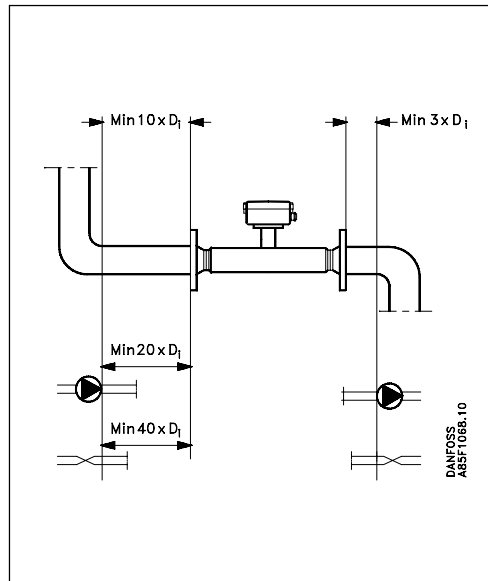

To maximise performance it is necessary to have straight inlet and outlet conditions, and a certain distance between the meter and bends, pumps, and valves. It is also important to centre the flowmeter in relation to pipe flanges and gaskets.

Valves must always be placed after the flowmeter. The only exception is when installing the sensor in a vertical pipe. In this case a valve below the sensor is necessary to allow zero-point adjustment. It is important to select a valve which has no impact on the flow when fully open.

#### Recommended inlet:

Fully open valve without any restriction to the flow: min.  $10 \times$  pipe diameter.

Partly open valve: min.  $40 \times$  the pipe diameter.

Pumps: min.  $20 \times$  pipe diameter.

Bends: min.  $10 \times$  pipe diameter.

Recommended outlet:  $3 \times$  pipe diameter.